

APPLICAZIONI PTO/POMPA PTO/PUMP ADAPTORS

11400011836

Applicazione PTO ISO/POMPA EST STANDARD - Adaptor ISO PTO/EST STANDARD PUMP

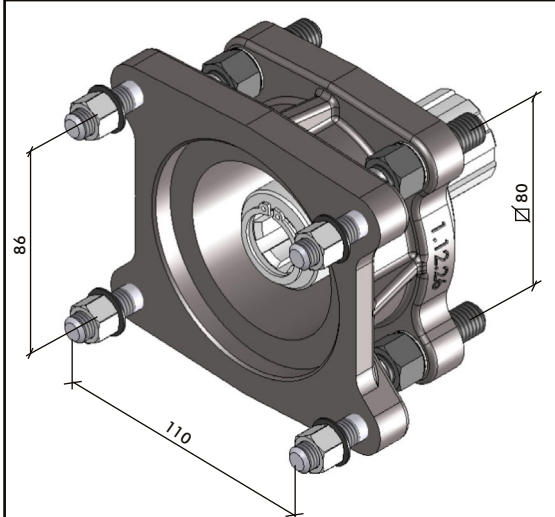

Coppia teorica trasmissibile
Theoretical transmitted torque
400 Nm

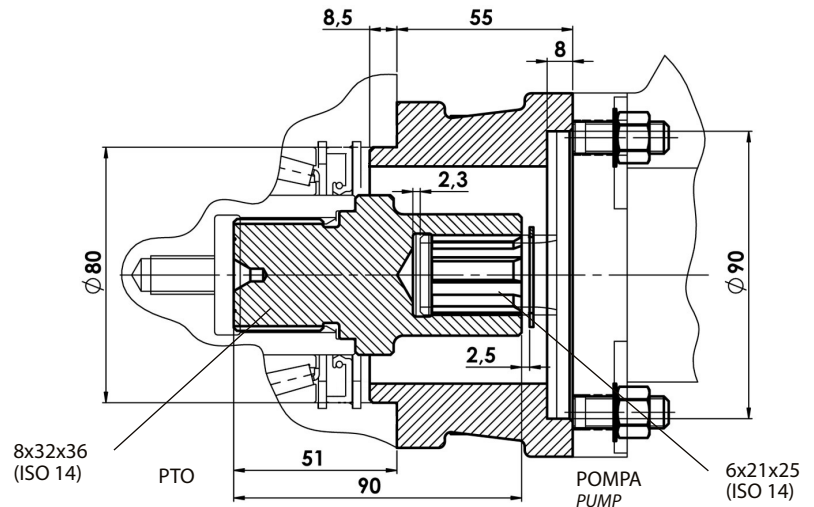

11400011952

Applicazione PTO EST STANDARD/POMPA ISO - Adaptor EST STANDARD PTO/ISO PUMP

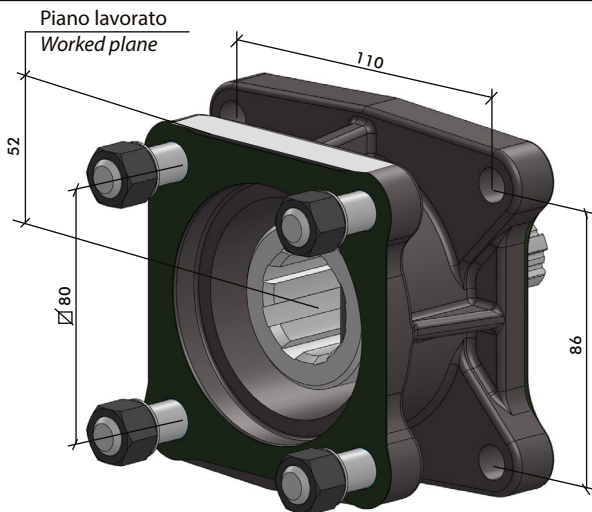

Coppia teorica trasmissibile
Theoretical transmitted torque
300 Nm

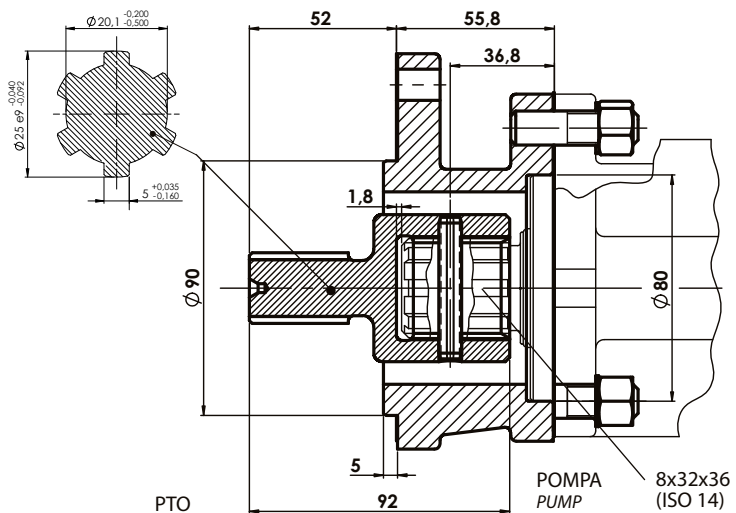

07/03/2022

Codice foglio: 9971141701 Rev: AV

pag.10

**COMPANY WITH
QUALITY SYSTEM
CERTIFIED BY DNV GL
= ISO 9001:2015 =**

O.M.F.B. S.p.A. Hydraulic Components
We reserve the right to make any changes without notice.
Edition 2021.02 No reproduction, however partial, is permitted.
Via Cave, 7/9 25050 Provaglio d'Iseo (Brescia) Italy Tel.: +39.030.9830611
Fax: +39.030.9839207-208 Internet: www.omfb.it e-mail: contatti@omfb.it

OMFB
HYDRAULIC COMPONENTS