

INVERTITORE DI GIRI ROTATION REVERSER

CODICE FAMIGLIA
FAMILY CODE

102003

Invertitore di giri idoneo per il montaggio diretto su PTO con uscita ISO 4 fori disponibile in 4 differenti rapporti. Uscita ISO 4 fori adatta sia per il montaggio diretto della pompa che della flangia di trasmissione.
Rotation reverser range for direct mounting on ISO 4 bolt PTO output, available in 4 different ratios. ISO 4 Bolt output is suitable for both direct pump installation or flange output direct.

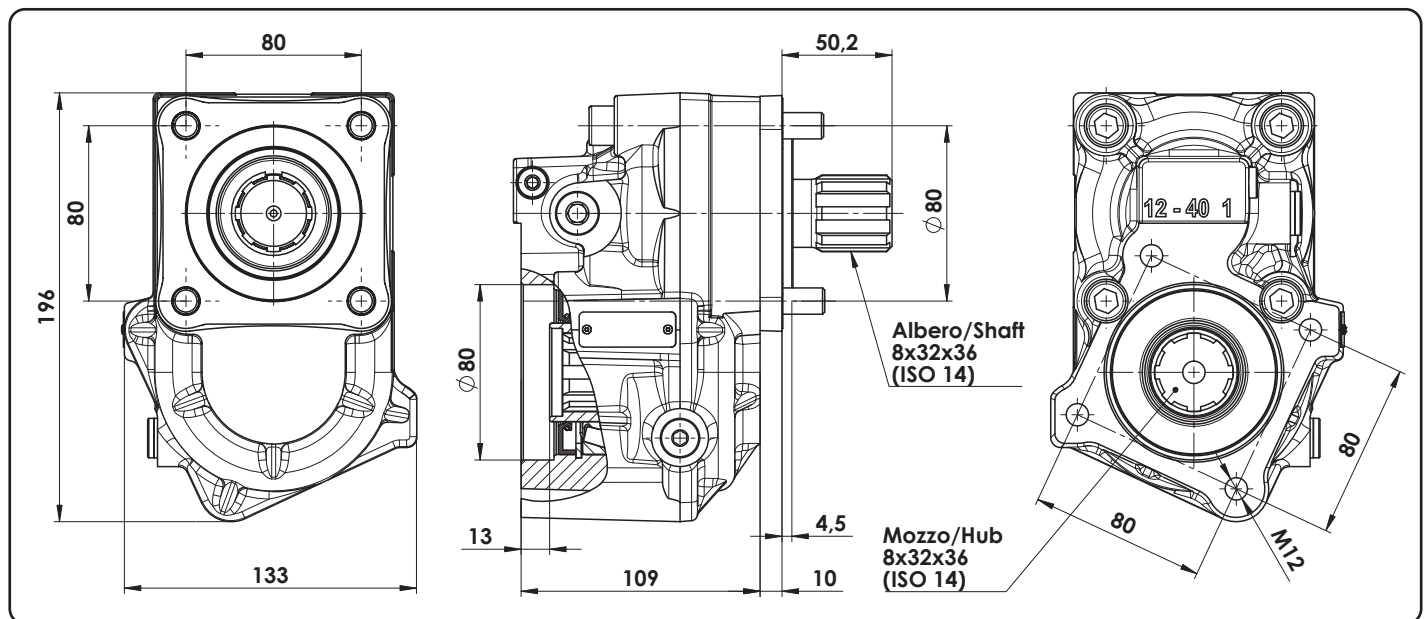
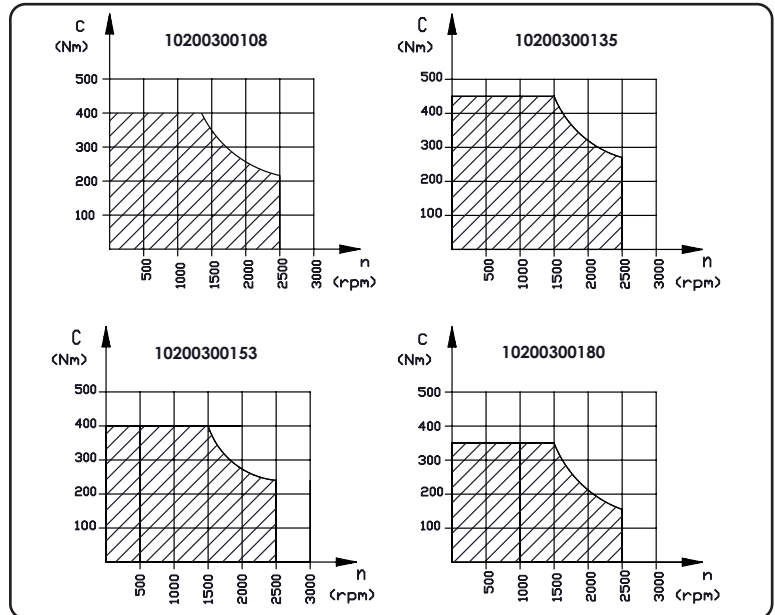
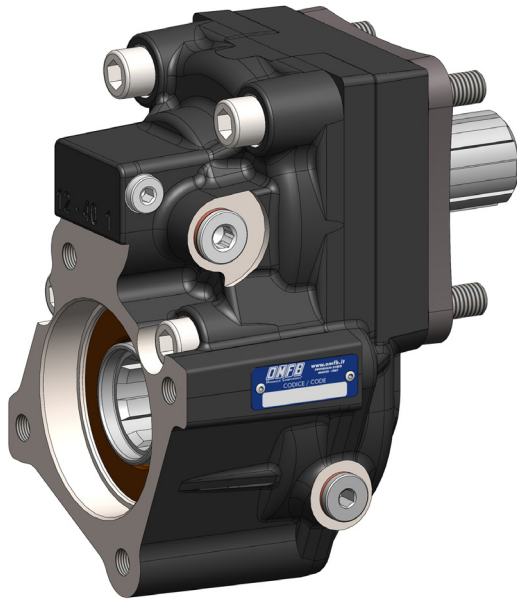

Codice Code	Rapporto interno Internal ratio	Versione Version	Potenza max. prelevabile Max. power	Coppia massima Max torque	Peso Weight
10200300108	1:1,04	17	56 kW	400 Nm	11Kg
10200300135	1:1,33		69 kW	450 Nm	
10200300153	1:1,53		62 kW	400 Nm	
10200300180	1:1,80		54 kW	350 Nm	

pag.1

O.M.F.B. S.p.A. Hydraulic Components

We reserve the right to make any changes without notice.

Edition 2020.02 No reproduction, however partial, is permitted.

Via Cave, 7/9 25050 Provaglio d'Iseo (Brescia) Italy Tel.: +39.030.9830611

Fax: +39.030.9839207-208 Internet:www.omfb.it e-mail:info@omfb.it

30/03/2021

99710200317 Rev: AB





ATTENZIONE: rimuovere il paraolio della PTO prima di montare l'invertitore di giri per garantire un' adeguata lubrificazione dello stesso.

WARNING: to ensure a proper lubrication please remove the oil seal from the PTO output before fitting the rotation reverser

