

# PRESA DI FORZA A COMANDO PNEUMATICO

## PNEUMATIC CLUTCH POWER TAKE-OFF

**CODICE PTO**  
PTO CODE

**70-18**

**CAMBIO**  
GEARBOX

**HINO**

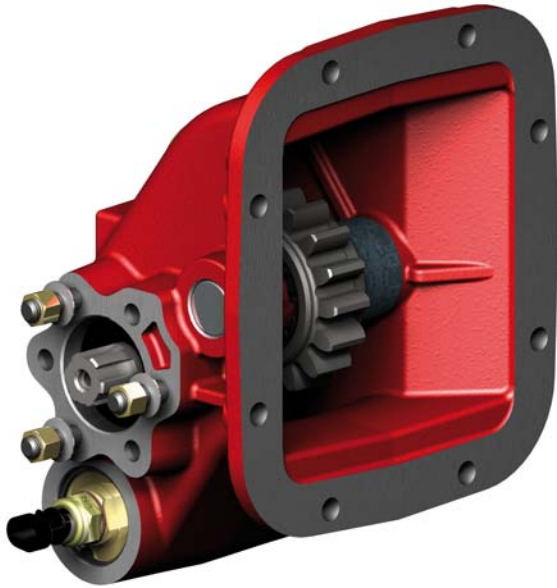

### DIAGRAMMA DI UTILIZZO WORKING CONDITION

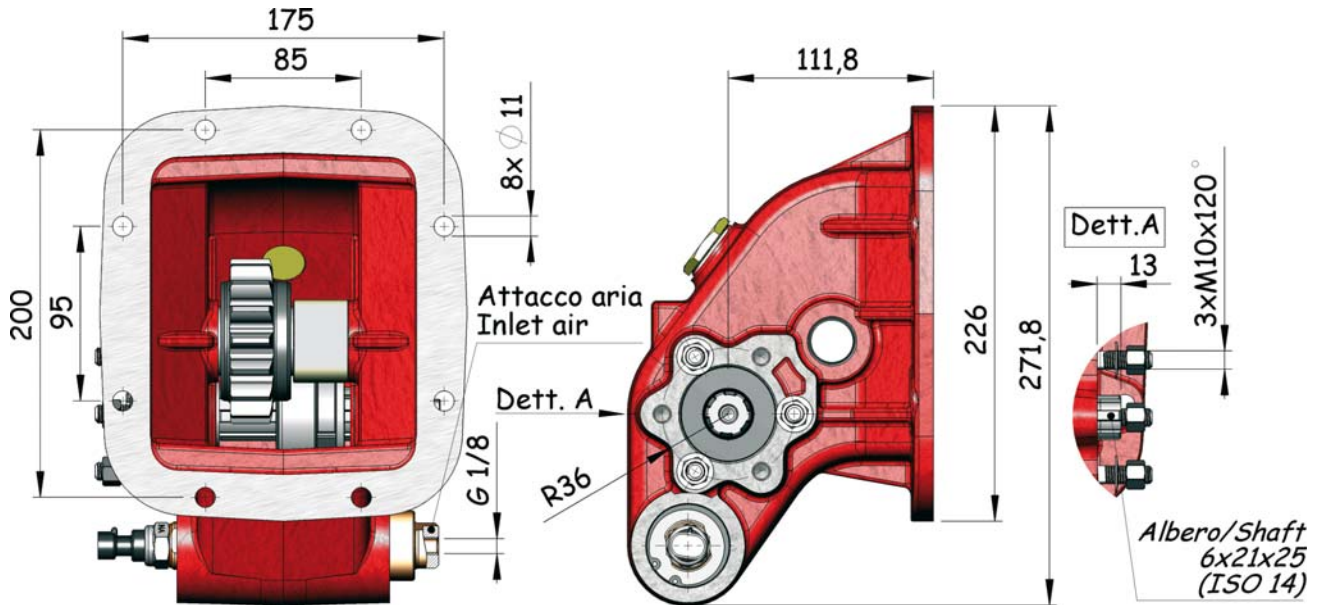
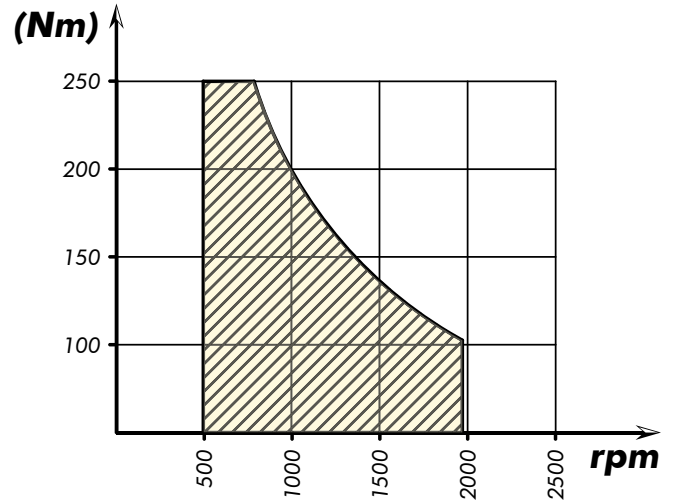

Tipo cambio Gearbox	Codice PTO PTO code	Versione Version	Giri pto a 1000 giri motore Pto ratio@1000 eng.rpm	Coppia massima Max torque	Lato montaggio Mounting side	Uscita Output	Rotazione Rotation	Kit di montaggio Mounting kit	Peso Weight
			rpm	Nm					Kg
<b>HX 07</b>	<b>70-18-137</b>	13	788	<b>250</b>	Sx Left	Poster. Rear	Ant. Acw	154-3-3222	13,3

pag.1