

**PRESA DI FORZA A
COMANDO MECCANICO
MECHANICAL CLUTCH POWER
TAKE-OFF**

CODICE PTO
PTO CODE

067-079-00131

CAMBIO
GEARBOX

MITSUBISHI



**DIAGRAMMA DI UTILIZZO
WORKING CONDITION**

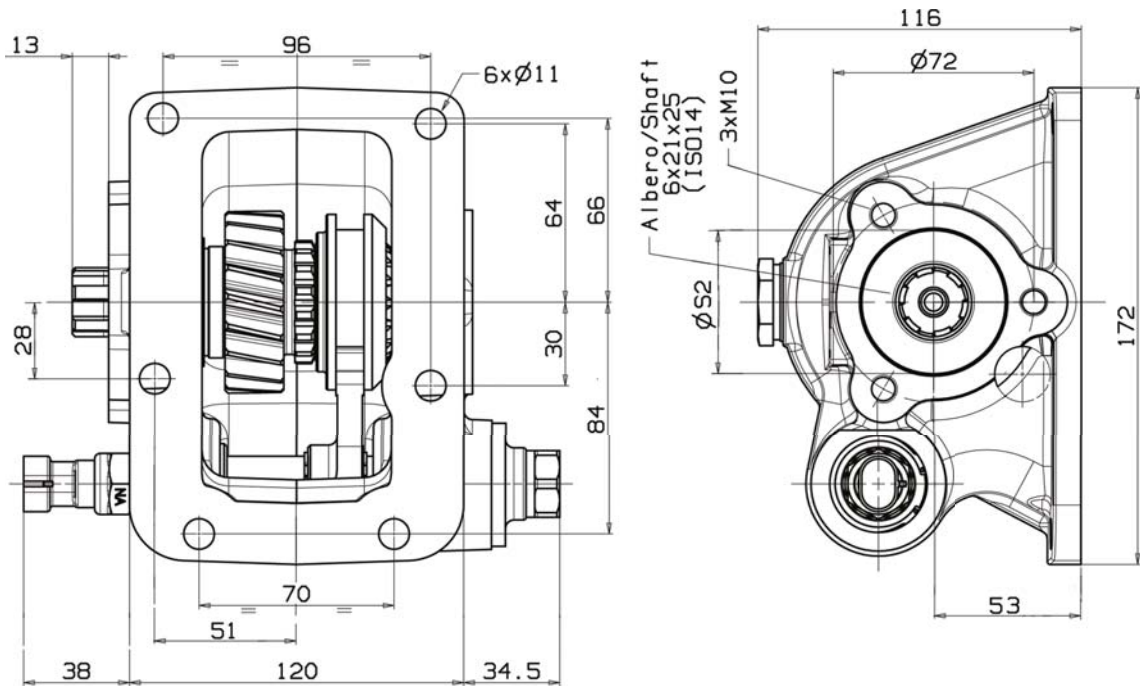
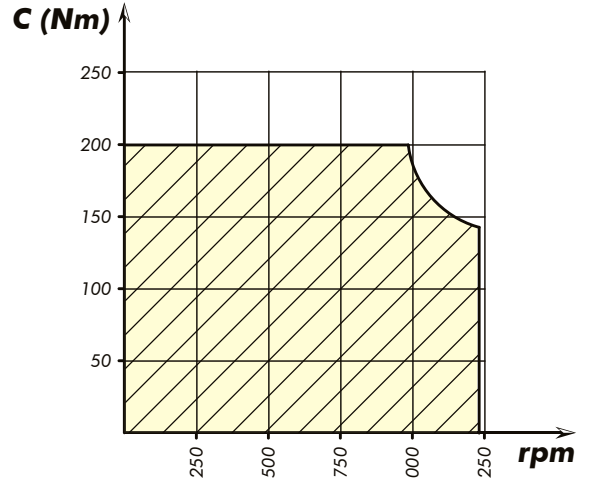

Tipo cambio Gearbox	Codice PTO PTO code	Versione Version	Giri pto a 1000 giri motore Pto ratio@1000 eng.rpm	Coppia massima Max torque	Lato montaggio Mounting side	Uscita Output	Rotazione Rotation	Kit di montaggio Mounting kit	Peso Weight
			rpm	Nm					Kg
M035-S5	067-079-00131	13	440	200	Sx Left	Post. Rear	Ora. Cw	154-3-3419	6,2